

Collection Delphinium 1998

TECHNICAL DATA SHEET



DELPHINIUM CHANDELIER ROUND DC100N

Chandelier Round

Art.nr.	Dimensions
DC80N	Ø 80cm, Height 45cm, Length chain 170cm, 10x E14, 21,0 kg, nickel finish
DC100N	Ø 100cm, Height 55cm, Length chain 170cm, 12x E14, 27,0 kg, nickel finish
DC120N	Ø 120cm, Height 70cm, Length chain 170cm, 16x E14, 35,0 kg, nickel finish
DC140N	Ø 140cm, Height 70cm, Length chain 170cm, 20x E14, 67,0 kg, nickel finish

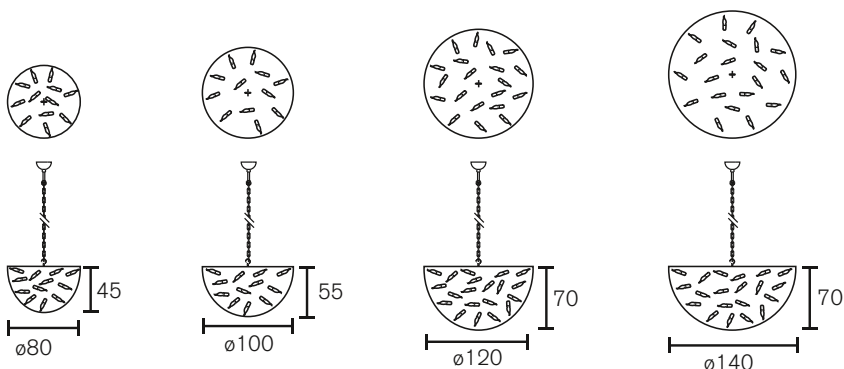

Chandelier Conical

Art.nr.	Dimensions
DCC60N	Ø 60cm, Height 70cm, Length chain 170cm, 8x E14, 20,0 kg, nickel finish
DCC70N	Ø 70cm, Height 80cm, Length chain 170cm, 10x E14, 25,0 kg, nickel finish

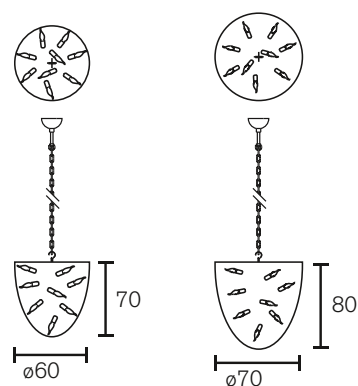

Chandelier Oval

Art.nr.	Dimensions
DOC60N	Length 120cm, Width 60cm, Height 55cm, Length chain 170cm, 12x E14, 27,0 kg, nickel finish
DOC70N	Length 140cm, Width 70cm, Height 55cm, Length chain 170cm, 12x E14, 29,0 kg, nickel finish
DOC80N	Length 160cm, Width 70cm, Height 55cm, Length chain 170cm, 16x E14, 40,0 kg, nickel finish
DOC100N	Length 200cm, Width 70cm, Height 70cm, Length chain 170cm, 20x E14, 58,0 kg, nickel finish

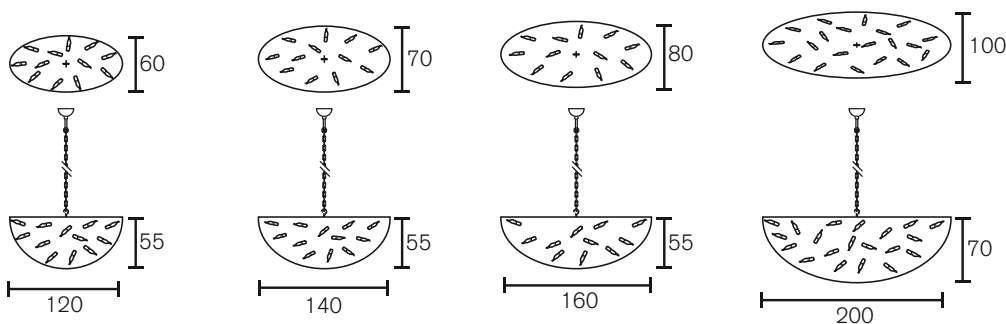

All chandeliers are supplied with 2 meter electrical cable and a ceiling shade.

Ceiling Lamp Round

Art.nr.	Dimensions
DP60N	Ø 60cm, Height 30cm, 5x E14, 11,0 kg, nickel finish
DP80N	Ø 80cm, Height 35cm, 6x E14, 17,0 kg, nickel finish
DP100N	Ø 100cm, Height 40cm, 8x E14, 26,0 kg, nickel finish
DP120N	Ø 120cm, Height 40cm, 10x E14, 40,0 kg, nickel finish

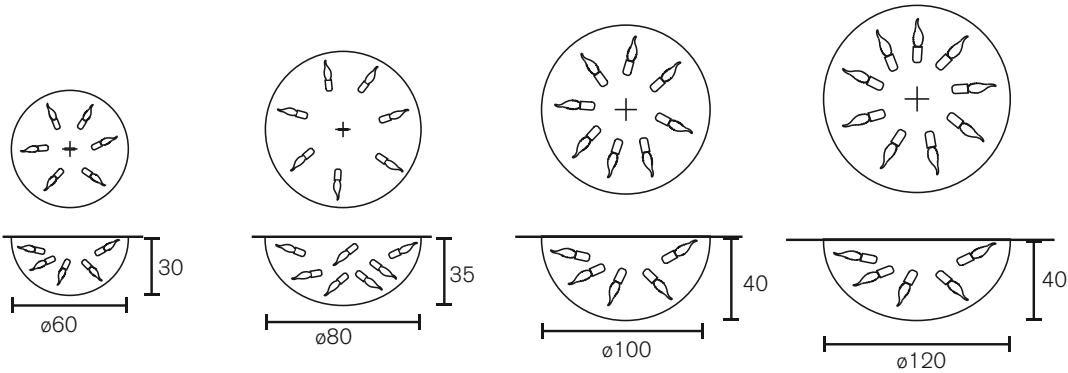
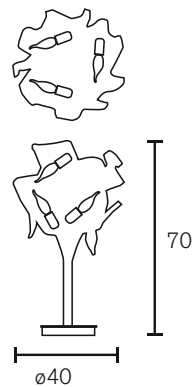

Table Lamp

Art.nr.	Dimensions
DT40ST	Ø 40cm, Height 70cm, 3x E14, 10,0 kg, stainless steel



Wall Lamp

Art.nr.	Dimensions
DW20N-L	Width 13cm, Height 40cm, Depth 10cm, 1x E14, 3,0 kg, nickel finish, left version
DW20N-R	Width 13cm, Height 40cm, Depth 10cm, 1x E14, 3,0 kg, nickel finish, right version
DW35N	Width 40cm, Height 75cm, Depth 20cm, 3x E14, 7,0 kg, nickel finish

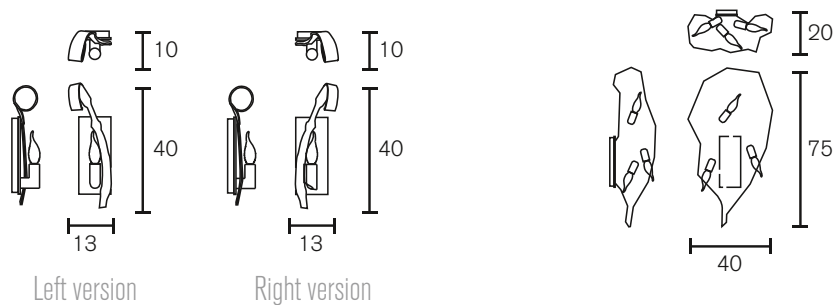

All chandeliers are supplied with 2 meter electrical cable and a ceiling shade. The table lamp is supplied with a dimmer.

BRAND VAN EGMOND B.V. Nikkelstraat 41, 1411 AH Naarden, the Netherlands

+31 (0)35 692 12 59

+31 (0)35 691 17 25

info@brandvanegmond.com

www.brandvanegmond.com

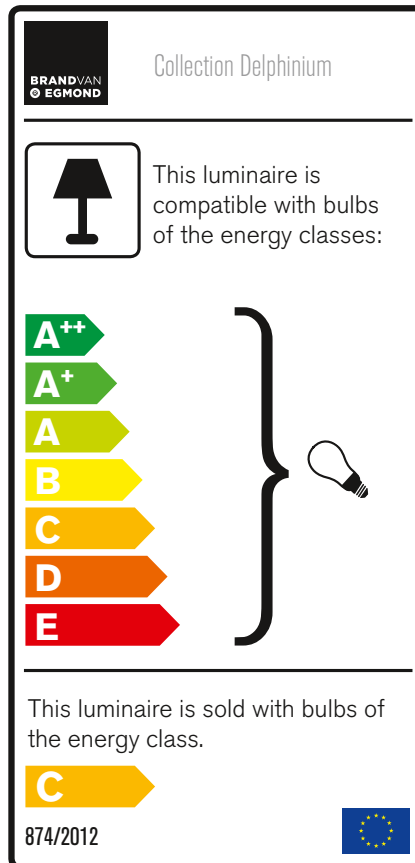

BRAND VAN EGMOND Collection Delphinium

This luminaire is compatible with bulbs of the energy classes:

A++
A+
A
B
C
D
E

This luminaire is sold with bulbs of the energy class.

C

874/2012 

The label features a lamp icon, a list of energy classes from A++ to E, a lightbulb icon, and the text 'This luminaire is sold with bulbs of the energy class.' with a highlighted 'C' class. It also includes the reference number 874/2012 and the EU flag.

Cleaning instruction

1. Cleaning by expert is advised.
2. Cut power before cleaning.
3. Clean with a soft dry cloth only or use a feather duster.
4. When using cleaning agent use a multi-surface spray cleaner on a soft cloth. Do not use abrasive cloths or substances and always read the label of any product you wish to use on or near a lamp by BRAND VAN EGMOND.